

## GREASE SEPARATORS



### GREASE

**Material:** PEHD  
**Colour(s):**

**Documents:**

Statement of approval of the product for use, as a custom-made product, in a civil structure

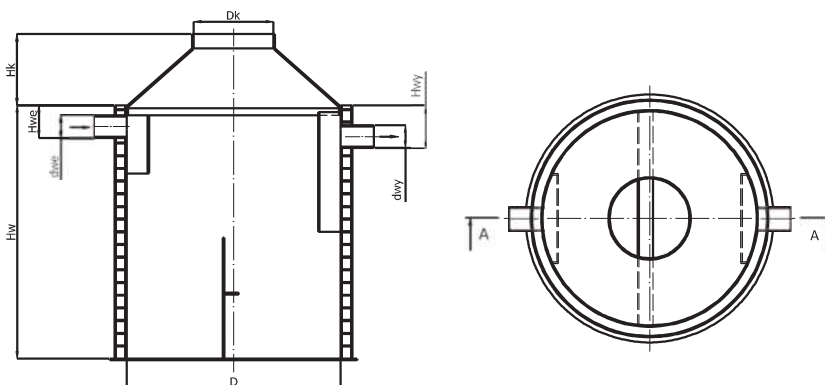

### GREASE SEPARATOR, BACKFILL: 1.5 M

CODE	TYPE	Q [l/s]	D [mm]	Hw [m]	dwe/dwy [mm]	hwe [mm]	hwy [mm]	Dk [mm]	Hk [m]
050 005 05	ST 00	0.5	600	910	110	160	210	800	1.5
050 010 05	ST 01	1	800	1010	110	160	210	800	1.5
050 020 05	ST 02	2	1000	1280	110	160	210	800	1.5
050 030 05	ST 03	3	1000	1680	110	160	210	800	1.5
050 040 05	ST 04	4	1200	1680	160	210	260	800	1.5
050 050 05	ST 05	5	1400	1680	160	210	260	800	1.5
050 060 05	ST 06	6	1400	1780	160	210	260	800	1.5
050 070 05	ST 07	7	1600	1780	160	210	260	800	1.5
050 080 05	ST 08	8	1800	1580	160	210	260	800	1.5
050 090 05	ST 09	9	1800	1680	160	210	260	800	1.5
050 100 05	ST 10	10	2000	1520	200	250	300	800	1.5
050 120 05	ST 12	12	2000	1770	200	250	300	800	1.5
050 140 05	ST 14	14	2200	1720	200	250	300	800	1.5
050 150 05	ST 15	15	2400	1645	225	275	325	800	1.5
050 160 05	ST 16	16	2400	1745	225	275	325	800	1.5
050 180 05	ST 18	18	2500	1795	225	275	325	800	1.5
050 200 05	ST 20	20	2600	1820	250	300	350	800	1.5
050 220 05	ST 22	22	2800	1820	250	300	350	800	1.5
050 240 05	ST 24	24	2800	1900	250	300	350	800	1.5
050 250 05	ST 25	25	3000	1820	250	300	350	800	1.5

The above table contains standard sizes.  
Custom sizes / dimensions are also available.